



The Linx 8900 series offers manufacturers a coding solution with the simplest, most intuitive user interface on the market, the fewest maintenance requirements and the most built-in features to ensure maximum uptime.

## LINX 8900

Our lineup of Linx small character continuous inkjet (CIJ) print systems provides a wide range of solutions for high speed variable product identification coding.

### SEALED INDUSTRIAL PRINT HEAD

Extremely robust and eliminates the need to make manual adjustments that risk damaging critical print head components

### EASI-CHANGE SERVICE MODULE

Allows preventive maintenance servicing to be completed in 30 minutes by untrained technicians using onscreen instructions

### ICON-DRIVEN 10" COLOR TOUCHSCREEN

Intuitive high-resolution user interface and customizable home screen saves time while creating and editing messages

### EXTENDED SELF-SERVICE INTERVALS

Operate system up to 18,000 hours or 24 months between service interventions

**FOXJET**<sup>®</sup>

# TECHNICAL DATA

Print head	Mk11 Midi, Mk11 right-angle	
Print head – conduit options	2M (standard), 4M, 6M	
Max lines of print	8900/8910:	3 lines
	8920/8940:	5 lines
Character height range	8900/8910:	0.07" - 0.34"
	8920/8940:	0.07" - 0.47"
Max speed single line	8900:	Up to 574 FPM
	8910/8920:	Up to 1,433 FPM
	8940:	Up to 1,791 FPM
Ink delivery system	Fluid cartridges	
Automatic date codes, sequential numbering	8900/8910:	Single range
	8920/8940:	Multiple ranges
Graphics/Logo printing	Yes, via imported bitmap files using USB port	
Barcodes	ITF 2 of 5, Code 39, Code 128, EAN 8, EAN 13, UPCA, Pharmacode, Data Matrix, QR Code	
Ingress protection rating	8900/8910/8920: IP55 8940: IP65	



# FEATURES & BENEFITS

- Automatic print head flushing enables up to 100 starts and stops between recommended cleanings.
- Simple one-touch fluid cartridge refills during printing allows for no mess, no tools and no mistakes.
- Automatic fluid monitoring allows for 12-hour advanced fluid refill warnings, requiring less unplanned downtime and less line-operator monitoring.
- Extended shutdowns of up to 3 months without the need to flush or drain the printer are possible.
- Prints 3 to 5 lines of alphanumeric text on virtually any material.
- Effortless product changeovers are made by storing and easily retrieving multiple production line settings.

# TECHNICAL DRAWINGS

## Print head

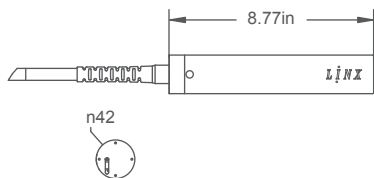

## Printer

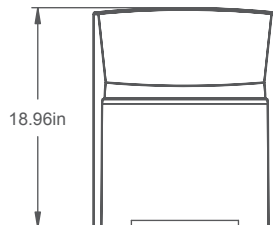

Front

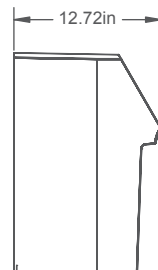

Side

## Trolley setup

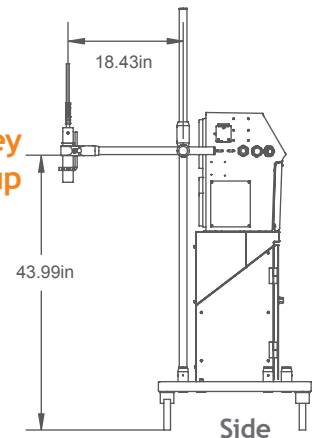

Side

1 Research Park Drive • St. Charles, MO 63304-5685  
 800.369.5384 • [foxjet.com](http://foxjet.com) • [info@foxjet.com](mailto:info@foxjet.com)

